

OWNER'S MANUAL

Model: LG-3025-QR (5302322)
(25 Gallon Lawn & Garden/ATV Boomless Sprayer)

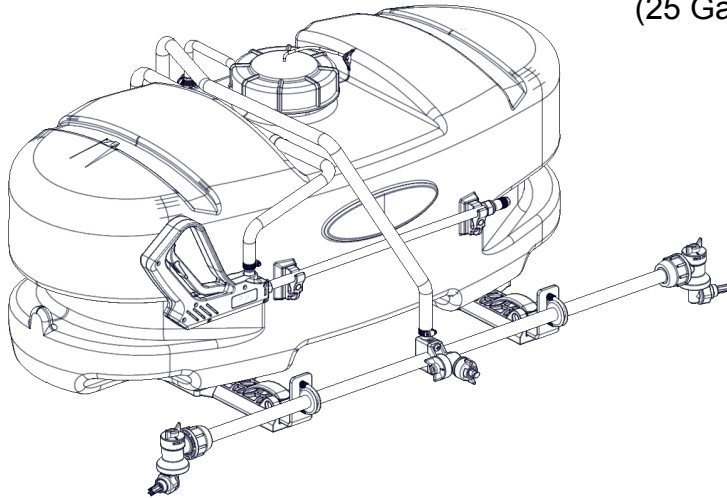

Technical Specifications

- 25 Gal. Corrosion-Resistant Polyethylene Tank
- 12 Volt Diaphragm Pump, 3.8 g.p.m.—45 psi
- Deluxe Pistol Grip Handgun
- 15 Ft. Handgun Hose (3/8" I.D.)
- 26 Ft. Vertical throw, 35 Ft. Horizontal Throw
- 30 Foot Spray Coverage w/Boom
- Corrosion-Resistant Nozzles

Caution: When fully filled with water, this sprayer will weigh 260 lbs.. Consult the owner's manual for your vehicle to verify that you are within it's load carrying capacity.

Assembly Instructions

- Make sure the contents of the sprayer's carton match the items shown on page 2 of the manual.
- Follow the steps on pages 3 & 4 to properly assemble the sprayer.
- After assembly is complete and before testing your sprayer, make sure you connect the electrical hook-up to the end of your pump and clip the clips to a fully charged battery. The red wire must be connected to the positive (+) and the black wire should be connected to the negative (-).
- The drain plug assembly should already be attached to the tank

**BEFORE RETURNING THIS PRODUCT
FOR ANY REASON, PLEASE CALL
1-800-831-0027**

**IF YOU SHOULD HAVE A QUESTION OR
EXPERIENCE A PROBLEM WITH YOUR
FIMCO INDUSTRIES PRODUCT:
1-800-831-0027**

**BEFORE YOU CALL, PLEASE HAVE THE
FOLLOWING INFORMATION AVAILABLE:
SALES RECEIPT & MODEL NUMBER. IN MOST
CASES, A FIMCO INDUSTRIES EMPLOYEE CAN
RESOLVE THE PROBLEM OVER THE PHONE.**

General Information

Thank you for purchasing this product. The purpose of this manual is to assist you in operating and maintaining your lawn & garden/ATV sprayer. Please read it carefully, as it furnishes information which will help you achieve years of trouble-free operation.

Warranty

Products are warranted for one year from date of purchase against manufacturer or workmanship defects for home owner usage and 90 days for commercial usage.

For technical assistance, visit our website @ www.fimcoindustries.com or call: **TOLL FREE @ 1-800-831-0027**

Our Technical Support Representatives will be happy to help you.

To obtain prompt, efficient service, always remember to give the following information...

- Correct Part Description and/or part number
- Model #/Serial # of your sprayer

Part descriptions and numbers can be obtained from the illustrated parts list section(s) of this manual.

IMPORTANT REMINDER

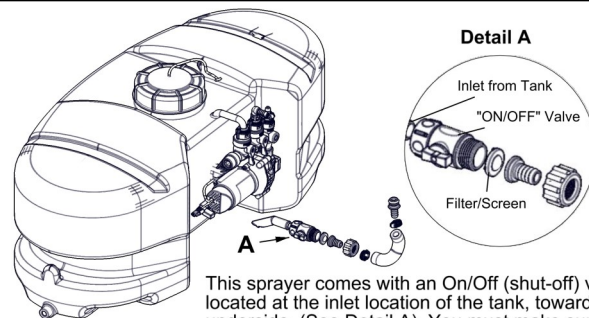

This sprayer comes with an On/Off (shut-off) valve located at the inlet location of the tank, towards the underside. (See Detail A). You must make sure the valve is in the "open" position before using your sprayer.



www.fimcoindustries.com

1000 FIMCO Lane, P.O. Box 1700, North Sioux City, SD 57049

Toll Free Phone: 800-831-0027 : Toll Free Fax: 800-494-0440

[5008430

(04/16)]

Contents of your sprayer's carton (LG-3025-QR - 5302322):

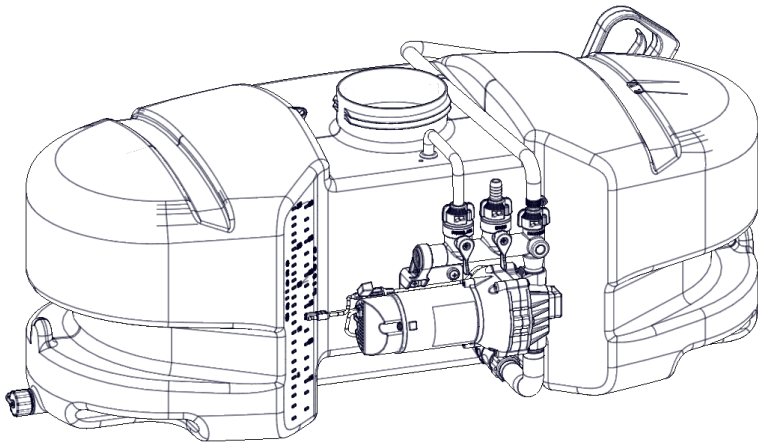

Tank/Plumbing Pre-Assembly

Owner's Manual

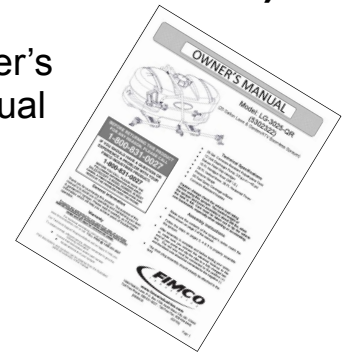

Lid w/Lanyard (#5058188)

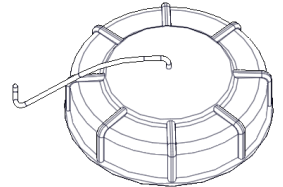

"Wet Boom" Sub-Assembly (5275712)

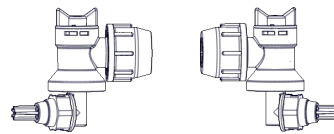

End Nozzle (5275122)
Pkg. of 2: #5275713

Contents of Parts Bag #5278137

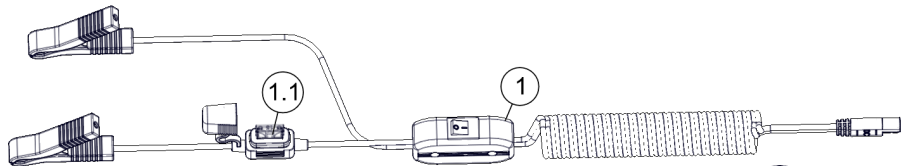

Ref. #	Part #	Description	Qty
1	5278114	Lead Wire Assembly w/15A Fuse & 30A Clips (96" Long)	1
1.1	5157238	15 Amp Regular Blade Fuse	1
2	5167097	2" Dry 100# Back Mount Gauge	1
3	5051114	Hose Clamp, 1/2"	2
4	5053112	Handgun Clip - Deluxe	2
5	5117334	#10-24 x 1/2" Machine Screw, Phillips Round Head	2
6	5034220	Round U-Bolt, 5/16"-18 x 1 5/16" x 1 3/4"	2
7	5034149	5/16-18nc x 3/4" lg Flat Head Screw (100) W/Locking Patch	4
8	5006307	5/16"-18 Hex Whiz (Flange) Locknut	4

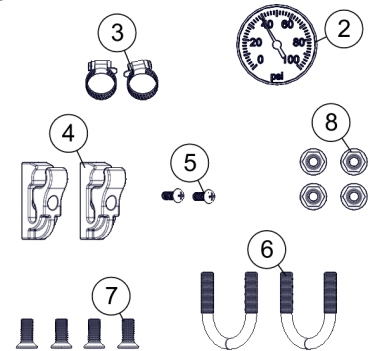

Contents of Bracket Kit #5278138

Ref. #	Part #	Description	Qty
1	5278222	ATV Quick Release Bracket Assembly	2
2	5038873	Quick Release Boom Mount Bracket	2
3	5020570	Hose, 1/2"-1 Brd. x 48"	1

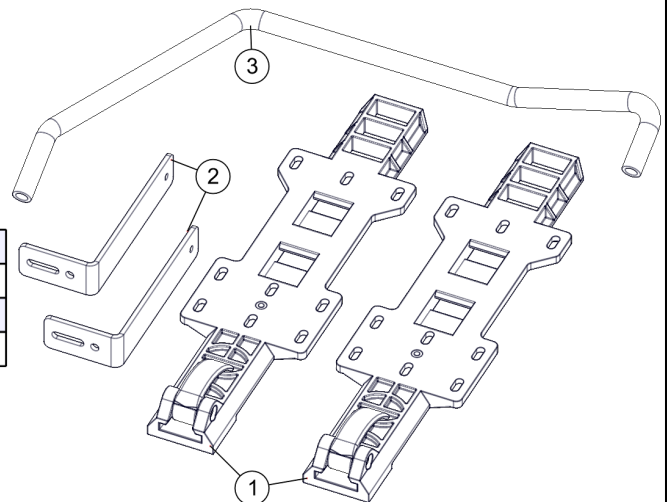

Step 1

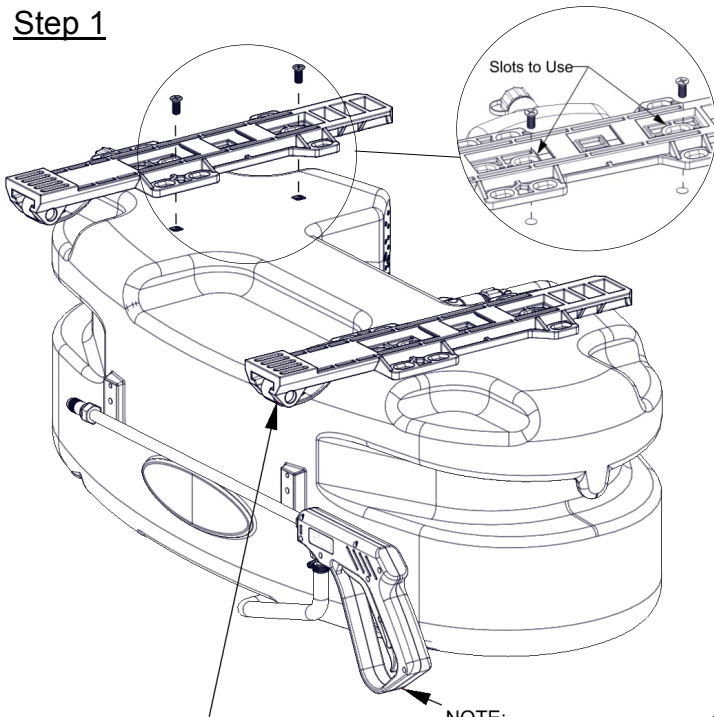

(**) 'Long' portion of the brackets should be facing towards the 'back' side of the tank (opposite of the pump/manifold assembly)

NOTE:
The Spray Gun will already be attached to the spray line hose

Assembly Procedure (LG-3025-QR)

Normally, the sprayer will be mounted on an ATV with the pump assembly at the operator's back and the spray wand will be at the rear of the unit. Right Hand (RH) and Left Hand (LH) sides of the sprayer are determined as if you are standing behind the sprayer, looking at it (facing forward)

After removing the tank from the box, start the assembly procedure by turning the tank upside down on a stable, flat surface.

A phillips head screwdriver is required for this step.

(**) Mount tank brackets (5278222) to the underside of the tank as shown in Step 1. Use (4) flat head screws (5034149) to secure it to the tank. The tank will rest on the surface of the brackets. Make sure the brackets are parallel with each other before tightening down the bolts. Do not over-tighten.

Step 2

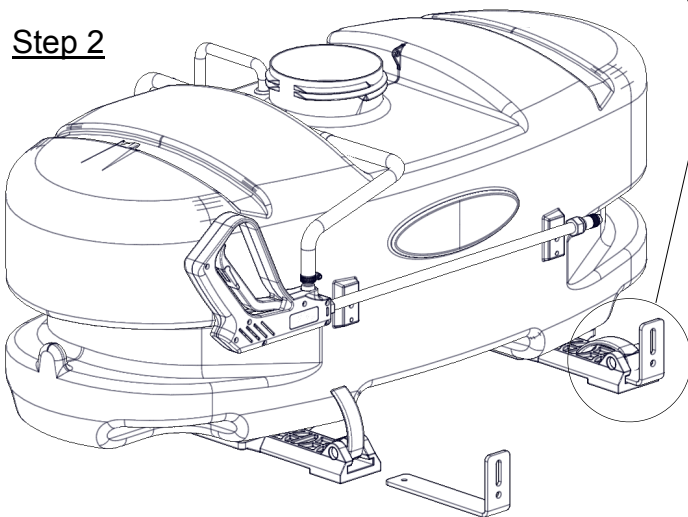

Detail A

After your tank brackets are securely attached, turn the tank assembly over and position it so that the cam handles which extend beyond the back of the tank are facing you and just hanging over the edge of the table or flat surface you are assembling this on.

Secure the boom mounting brackets (5038873) to the tank mounting brackets with Cam handles as shown in Detail A. You can position them as needed within the slot on the bracket. Just be sure that the surfaces of both brackets are even with each other.

You are now ready to mount this unit to an ATV, using ratchet straps (NOT INCLUDED)

Step 3

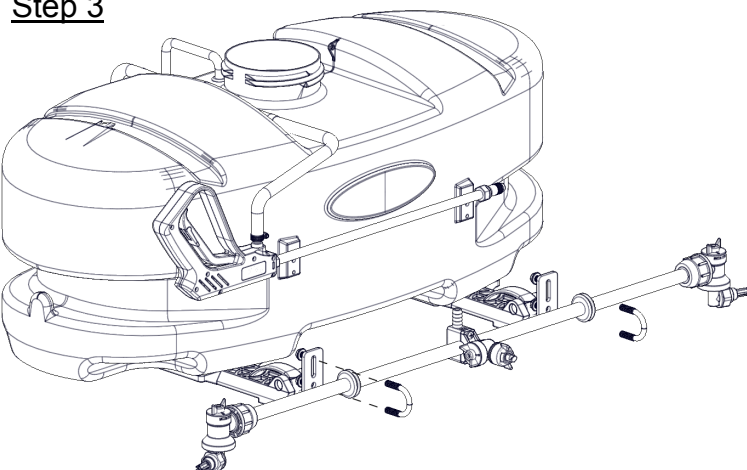

Attach the boom to the boom mounting brackets with the (2) u-bolts and (4) whiz locknuts. Make sure the u-bolts are positioned within the grooves of the grommets on the boom tube

NOTE: The purpose of these grommets is to prevent metal-to-metal contact between the u-bolts, boom tube and boom mounting brackets.

The grommets will 'compress' as you tighten the whiz locknuts onto the u-bolts. Tighten just so that the boom tube will NOT rotate within the grommets. Alternate the tightening of the locknuts to provide even pressure on the grommet.

****DO NOT OVER TIGHTEN the whiz locknuts, as this may cause the boom tube to flatten slightly!**

Step 5

Assembly Procedure (LG-3025-QR)

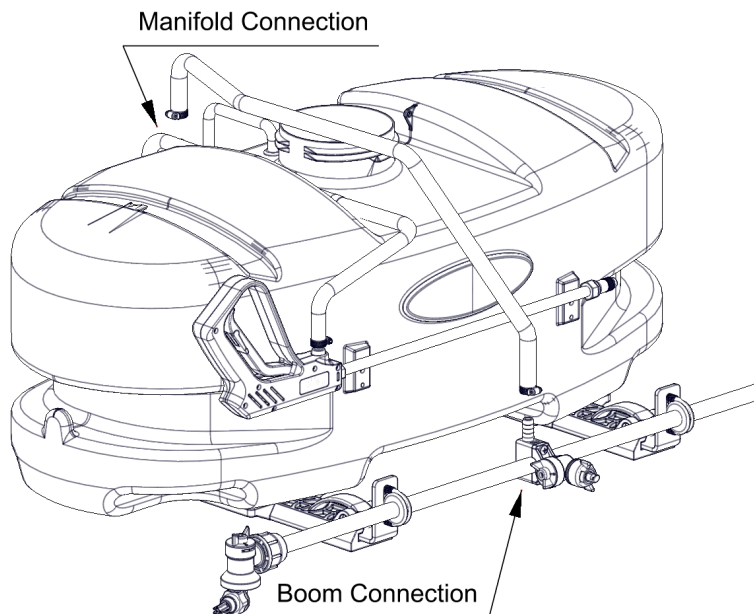

After your boom is attached, locate the 48" hose and the (2) hose clamps from the parts bag.

Place the hose clamps over each end of the hose loosely. Slip the ends of the hose over the hose barbs on both the manifold and on the center nozzle. Use a twisting motion, if necessary, to get the hose fully onto each barb. Bring the hose clamps to the connection point and tighten securely.

NOTE:

Make sure this boom feeder hose does not end up on the 'outside' of the spray wand hose, otherwise unwrapping the spray wand hose from around the tank may be difficult.

Detail A: Install the pressure gauge. Hand tighten securely. **** DO NOT OVER-TIGHTEN ****

Detail B: Screw the lid onto the tank. Place the end of the lanyard through the tab in the tank. This is so the lid can 'hang' off the tank when filling/rinsing the tank out.

Detail C: Locate the (2) clips and (2) phillips head machine screws from the parts bag.

A phillips head screwdriver is required for this step
Place a screw through the hole in the clip and bring it up to the tank, where the embossments for the clips are (located on the rear side of the tank)
Secure the clip/screw to the tank. Tighten so that the clip is secure. Do this for each clip.

**** DO NOT OVER-TIGHTEN ****

The spray wand will snap into the clips once installed. Do not use excessive force when placing the spray wand into the clips, as this could cause the clips to break.

Step 6

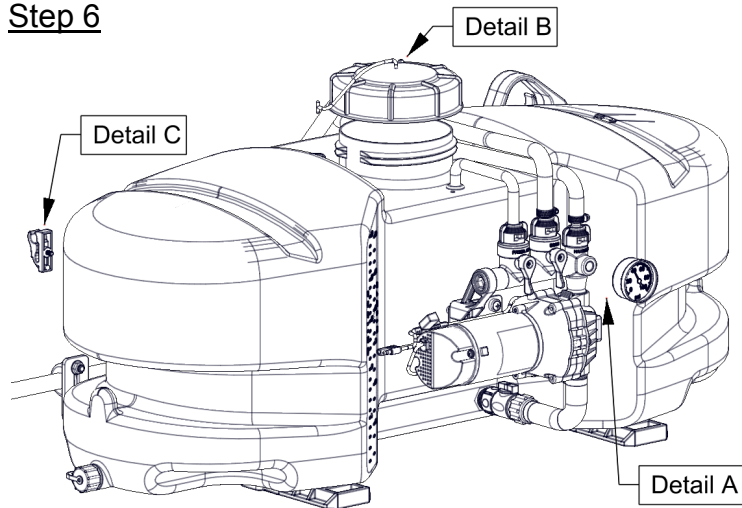

DETAIL A

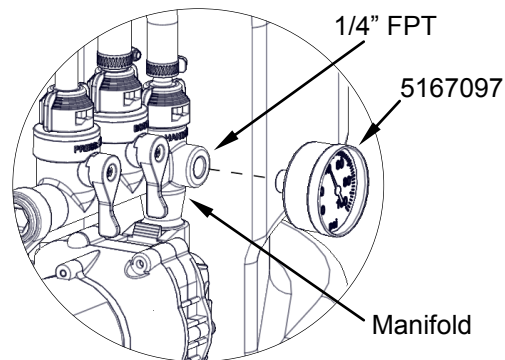

DETAIL B

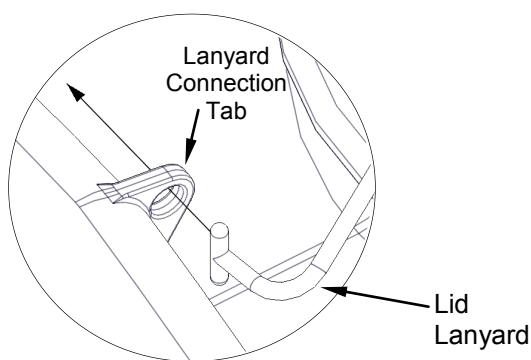

DETAIL C

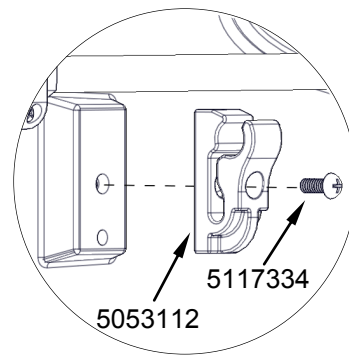

***** The Sprayer should now be ready for use *****

Testing the Sprayer

NOTE: It is important that you test your sprayer for leakage and proper spray patterns with plain water before chemical application is attempted. This will also give you the opportunity to familiarize yourself with the operation of the sprayer, without the possibility of losing any expensive chemicals.

Add water to the tank and drive to the starting place for spraying. When you are ready to spray, position booms for spraying and turn the boom valve to the "on" position. This will start solution spraying from the tips of the boom. The pressure will decrease slightly when the boom is spraying. Adjust the pressure by turning the "ON/OFF" valve lever on the bypass line valve.

Read the operating instructions and initially begin spraying by closing the 'bypass' valve and opening the boom line valve. This will enable the air in the line to be eliminated (purged) through all the tips, while building pressure. When everything tests all right (no leaks and good pressure), add the desired chemicals to the mixture and water combination and start your spraying operation. Adjust the pressure and spray as you did in the testing procedure.

Conditions of weather and terrain must be considered when setting the sprayer. Do not spray on windy days. Protective clothing must be worn in some cases

Be sure to read the chemical label(s) before application!

Operation

The pumping system draws solution from the tank, through the strainer and to the pump. The pump forces the solution under pressure to the handgun or boom nozzles.

Connect the lead wire to a fully charged 12 volt battery. You may use either a stand-alone battery or the battery on your towing vehicle. The lead wire has an On/Off switch to activate the pump. "-" is on and "O" is off.

Fill the tank part way with water and then add the desired amount of chemical to be sprayed. Finish filling tank to proper level. Turn the pump on by depressing the "-" side of the rocker switch. The pump is equipped with a pressure switch that is pre-set at the factory to shut the pump off when all discharges are closed.

The pump will turn back on when one of the following actions occurs: the handgun lever is squeezed to spray the handgun, or the boom valve is opened to broadcast spray with the boom, or the bypass valve is opened to re-circulate solution back into the tank.

When spraying with either the boom or the handgun, pressure may be reduced by slowly opening the bypass valve until desired pressure is achieved. Opening the valve decreases pressure, closing the valve increases pressure. When spraying with the boom, the proper method to set the pressure is to open the boom valve completely and if a lower pressure is desired, then slowly open the bypass valve until that pressure is obtained.

For the safest and most efficient chemical application, you will need to calibrate your sprayer using the tip and speed charts. Once you have determined the proper speed and pressure settings, you will need to

Speed Chart			
Speed in M.P.H. (Miles Per Hour)	Time Required in seconds to travel a distance of		
	100 Ft.	200 Ft.	300 Ft.
1.0	68 sec.	136 sec.	205 sec.
2.0	34	68	102
3.0	23	45	68
4.0	17	34	51
5.0	14	27	41
6.0	11	23	34
7.0	9.7	19	29
8.0	8.5	17	26
9.0	7.6	15	23
10.0	6.8	14	20

consult your chemical label for the amount of chemical to be added to the tank. Read the entire label. Use only according to label directions.

- Activate the handgun by squeezing the handle lever
- Rotating the adjustable nozzle tip on the handgun will change the tip pattern from a straight stream to a cone pattern (fine mist)
- The (3) nozzles are fixed at 17-1/2" spacing
- All (3) nozzles spraying at the same time will allow a maximum coverage of 30 feet
- The center nozzle will spray an 80" swath
- Each of the (3) nozzles has a shutoff valve, so you can shut off each nozzle individually. This may help in achieving the actual coverage needed for your application.

Calibration

Chemical labels may show application rates in gallons per acre, gallons per 1000 square feet or gallons per 100 square feet. You will note that the tip chart shows 3 of these rating systems. Once you know how much you are going to spray, then determine (from the tip chart) the spraying pressure (PSI), and the spraying speed (MPH).

Determining the proper speed of the pulling vehicle can be done by marking off 100, 200 & 300 feet. The speed chart indicates the number of seconds it takes to travel the distances. Set the throttle and with a running start, travel the distances. Adjust the throttle until you travel the distances in the number of seconds indicated by the speed chart. Once you have reached the throttle setting needed, mark the throttle location so you can stop and go again, returning to the same speed.

Add water and proper amount of chemical to the tank and drive to the starting place for spraying

Using the Boom Nozzles

Four things must be considered before spraying with the boom.

1. How much chemical must be mixed in the tank.
 2. Rate of spray (gallons per acre to be sprayed).
 3. What pressure (p.s.i.) will be used.
 4. Speed traveled (mph) while spraying.
- * Refer to the chemical label to determine your chemical mixture
 - * See the tip chart to determine the pressure to be used. The chart will also show the speed used when spraying.
 - * Start the pump and open the valve to the boom nozzles.
 - * Check the spray pattern. Usually you can see the coverage better on a solid concrete surface, such as a driveway.
 - * The boomless nozzles should be approx. 33" above the objects being sprayed.

Rate Chart for Boomless Nozzle (Set of 3)								
Gallons per Acre Based on Water - 17-1/2" Spacing								
Pressure P.S.I.	Capacity G.P.M. (3 Nozzles)	1 MPH	2 MPH	3 MPH	4 MPH	5 MPH	6 MPH	8 MPH
20	1.68	28.0	14.0	9.4	7.0	5.6	4.7	3.5
30	2.05	34.4	17.2	11.4	8.6	6.9	5.7	4.3
40	2.40	39.6	19.8	13.2	9.9	7.9	6.6	5.0
Gallons per 1000 Sq. Ft. Based on Water - 17-1/2" Spacing								
Pressure P.S.I.	Capacity G.P.M. (3 Nozzles)	1 MPH	2 MPH	3 MPH	4 MPH	5 MPH	6 MPH	8 MPH
20	1.68	0.64	0.32	0.21	0.16	0.13	0.11	0.08
30	2.05	0.78	0.39	0.26	0.20	0.16	0.13	0.10
40	2.40	0.90	0.45	0.30	0.23	0.18	0.15	0.12
Gallons per 100 Sq. Ft. Based on Water - 17-1/2" Spacing								
Pressure P.S.I.	Capacity G.P.M. (3 Nozzles)	1 MPH	2 MPH	3 MPH	4 MPH	5 MPH	6 MPH	8 MPH
20	1.68	0.064	0.032	0.021	0.016	0.013	0.011	0.008
30	2.05	0.078	0.039	0.026	0.020	0.016	0.013	0.010
40	2.40	0.090	0.045	0.030	0.023	0.018	0.015	0.012

** The rate of spray as shown in the chart will remain the same with 1, 2 or 3 Nozzles **

The only difference will be with the width of the spray swath

STOP WARNING STOP

DO NOT USE PUMP IN AN EXPLOSIVE ENVIRONMENT. DO NOT USE TO PUMP FLAMMABLE FLUIDS, GASOLINE, KEROSENE, FUEL, OIL, ETC.

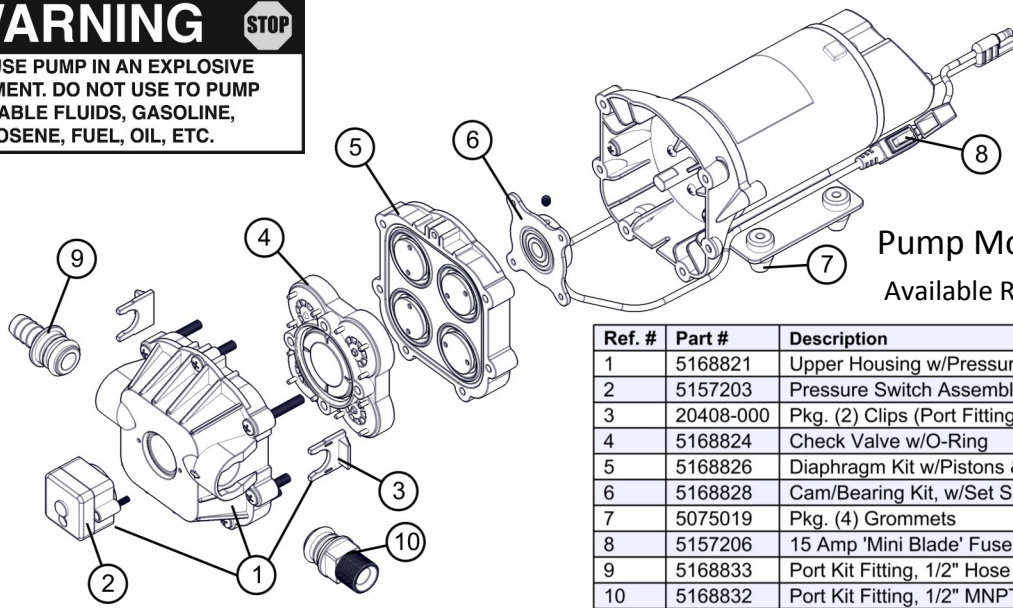

Pump Model: 5277982
Available Replacement Parts

Ref. #	Part #	Description	Qty
1	5168821	Upper Housing w/Pressure Switch	1
2	5157203	Pressure Switch Assembly	1
3	20408-000	Pkg. (2) Clips (Port Fitting)	1
4	5168824	Check Valve w/O-Ring	1
5	5168826	Diaphragm Kit w/Pistons & (4) Screws	1
6	5168828	Cam/Bearing Kit, w/Set Screw	1
7	5075019	Pkg. (4) Grommets	1
8	5157206	15 Amp 'Mini Blade' Fuse	1
9	5168833	Port Kit Fitting, 1/2" Hose Barb	1
10	5168832	Port Kit Fitting, 1/2" MNPT	1

DO

- Clean and rinse your pump after each use with Fimco Tank Neutralizer
- Winterize your pump or sprayer by rinsing, draining and running RV Antifreeze through it before storing for the winter.
- Use clean water for your spray mixture
- Store inside a building when not in use.

DON'T

- Use to pump bleach.
- Use to pump petroleum products such as diesel fuel, gasoline or kerosene
- Leave your pump sit with spray mixture in it for extended periods
- Use dirty or unfiltered water for spraying

CAUTION

PRESSURE SWITCH OPERATION

Pressure switch is pre-set at the factory. Improper adjustment of the pressure switch, may cause severe overload or premature failure. If the pump is subjected to rapid cycling during normal operation, or infrequent periods, damage may occur.

Troubleshooting the Pump:

- Motor does not run:
- Check for loose wiring connection(s).
 - Make sure the 'ON/OFF' switch in the lead wire assembly is in the 'ON' position. "I" is the 'ON' position and 'O' is the 'OFF' position.
 - Check for defective pressure switch. Make sure you are connected to a good 12 volt power source. Make sure any on/off switches are in the 'on' position.
 - Remove the cap to the pressure switch. Pull both red wires off of their terminals, and touch the two ends together. If your pump runs when you do this, your pressure switch will need to be replaced.
 - Check the fuse.
 - Check for low voltage at the power supply.
- Pump does not prime:
- Check for air leaks in supply line.
 - Check for debris in the check valve assembly.
 - Check for defective check valve.
 - Check for clogged strainer/filter.
 - Check for cracks in the pump housing.
 - Check for empty product supply.

Pump Specifications	
Current:	7.4 Amps @ 40 PSI
Check Valve:	Viton
Wetted Parts Housing:	Polypropylene
Diaphragm:	Santoprene
Liquid Temperature:	130° F max.

GPM=Gallons Per Minute
PSI=Pounds per Square Inch
DC=Direct Current

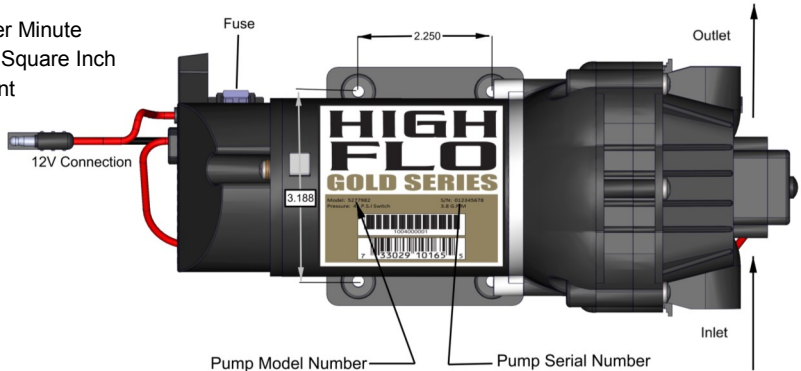

- Pulsating flow (surging):
- Check for defective pressure switch.
 - Check for leaks in the discharge line.
 - Check for restriction in the discharge line.
 - Check for debris in nozzle orifice.
 - Discharge hose may be too long.
 - Check for clogged strainer.

- Motor continues to run after discharge is shut off:
- Check for empty product supply.
 - Check for open bypass valve. (if equipped)
 - Check for low voltage.
 - Check for leak in discharge line.
 - Check for defective or dirty check valve.
 - Check for defective pressure switch.

Exploded View/Parts List: LG-3025-QR (5302322)

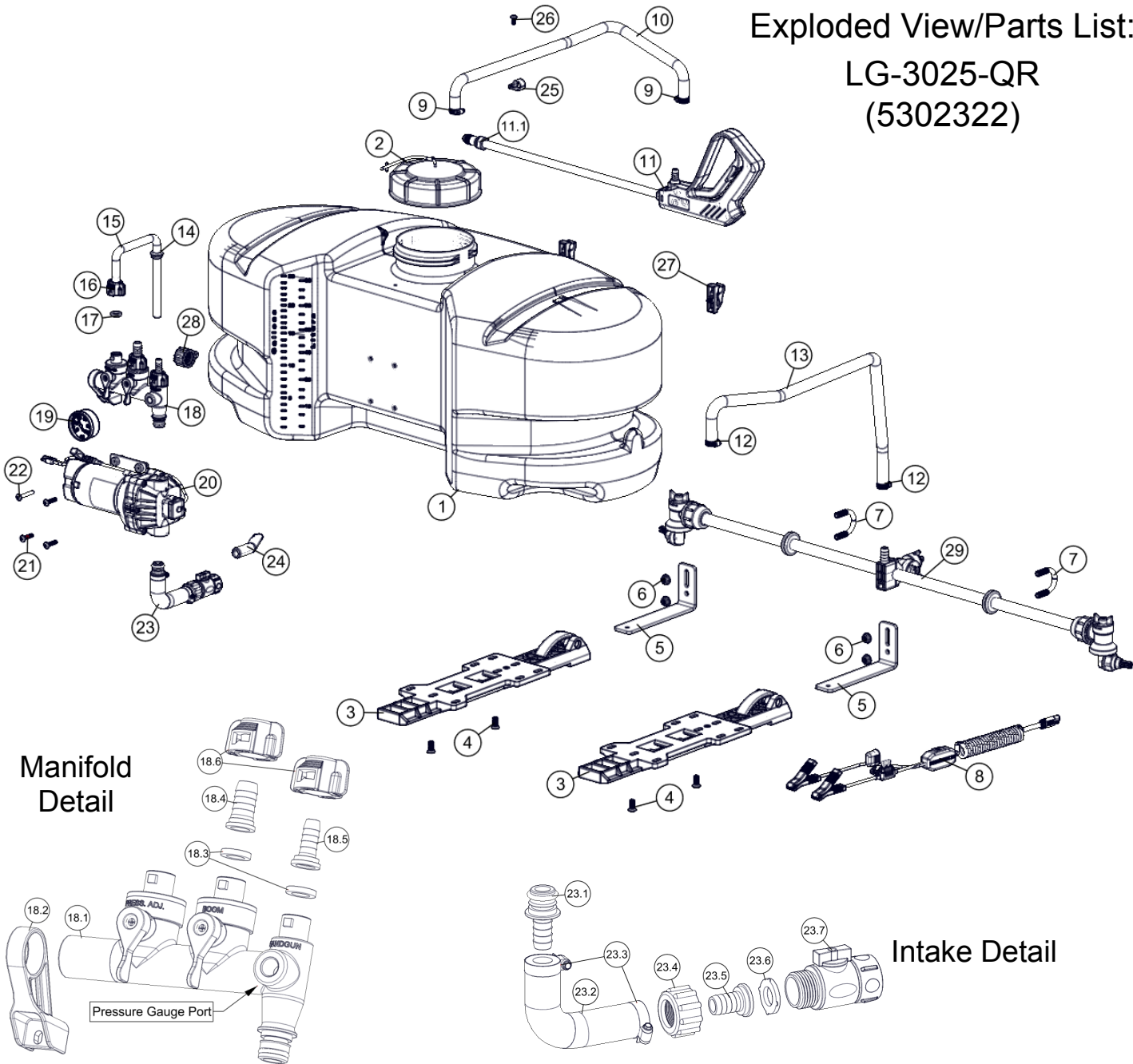

Manifold Detail

Intake Detail

Ref. #	Part #	Description	Qty
1	5169243	25 Gallon Tank (White)	1
2	5058188	Tank Lid w/Lanyard	1
3	5278222	ATV Quick Release Bracket Assembly	2
3.1	5078223	Cam Handle Assembly - for Quick Release Boom	1
4	5034149	5/16-18nc x 3/4" lg Flat Head Screw (100) W/Locking Patch	4
5	5038873	Quick Release Boom Mount Bracket - Fixed Height	2
6	5006307	5/16"-18 Hex Whiz (Flange) Locknut	4
7	5034220	Round U-Bolt, 5/16"-18 x 1 5/16" x 1 3/4"	2
8	5278114	Lead Wire Assembly w/15A Fuse & 30A Clips (96" Long)	1
8.1	5157238	15 Amp Regular Blade Fuse	1
9	5051144	Hose Clamp, 3/8"	2
10	5020524	Hose, 3/8"-1 Brd. x 15 Ft.	1
11	5273959	Deluxe Pistol-Grip Handgun w/X-26 Tip	1
11.1	5018331	Brass Handgun Tip (X-26)	1
12	5051114	Hose Clamp, 1/2"	2
13	5020570	Hose, 1/2"-1 Brd. x 48"	1
14	5075018	Grommet, 1/2" I.D.	1
15	5100822	Rigid By-Pass Tube Assembly	1
16	5143429	QC Manifold - QC Quarter Turn Cap	1
17	5143430	Flat Washer - Hose Barb Seal	1
18	5302349	Quick Connect Manifold Assembly	1
18.1	5302347	Quick Connect Manifold	1
18.2	5143422	QC Manifold - Support Bracket	1

Ref. #	Part #	Description	Qty
18.3	5143430	Flat Washer - Hose Barb Seal	2
18.4	5143432	QC Manifold - 1/2" Hose Barb - Straight	1
18.5	5143431	QC Manifold - 3/8" Hose Barb - Straight	1
18.6	5143429	QC Manifold - QC Quarter Turn Cap	2
19	5167097	2" Dry 100# Back Mount Gauge	1
20	5277982	Hi Flo Gold Series 3.8 GPM Pump	1
21	5117168	#10-24 x 1" Phillips Truss Head Machine Screw	3
22	5117338	#10-24 x 1 1/2 Long Truss Head Machine Screw	1
23	5275877	Intake Sub-Assembly	1
23.1	5168833	Port Kit Fitting, 1/2" Hose Barb	1
23.2	5020557	1/2" Polyspring Hose x 5 1/4"	1
23.3	5051114	Hose Clamp (3/8"-1/2")	2
23.4	5006209	Poly Knurled Swivel Nut, 3/4" FGHT	1
23.5	5149035	Poly Swivel, 1/2" Hose Barb	1
23.6	5116242	Strainer, 1" Filter Washer	1
23.7	5143419	Swivel Shut-Off	1
24	5100452	Siphon Tube	1
25	5051122	5/8" Black Nylon Loom Cable Clamp	1
26	5117234	#10-24 x 1/2" Phillips Truss Head Machine Screw	1
27	5278348	Deluxe Wand Clips & Screws (Pkg/2) (#10-24 Thread)	1
28	5274373	Drain Plug Cap, Tether, and Washer Assembly	1
29	5275260	"Wet Boom" Assembly	1

Boomless "Wet" Boom Assembly Exploded View/Parts List (5275260)

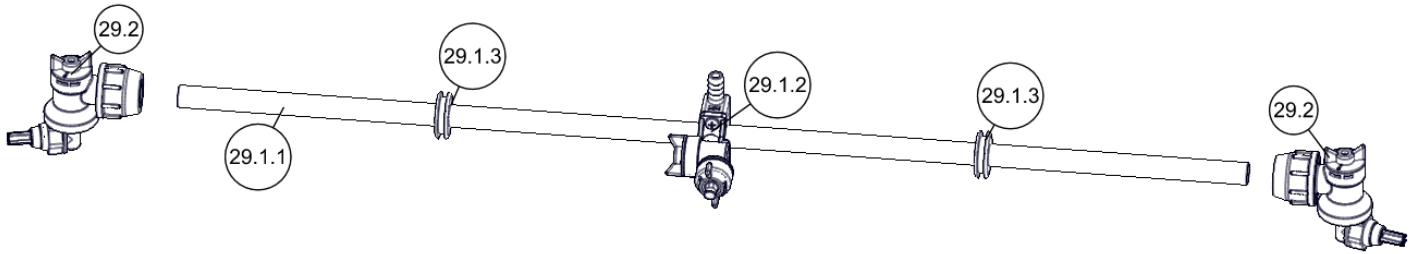

Ref. #	Part #	Description	Qty
29	5275260	"Wet Boom" Assembly	1
29.1	5275712	Wet Boom Sub-Assembly	1
29.1.1	5100316	Boom Tube	1
29.1.2	5275123	Center Nozzle Assembly (Wet Boom)	1
29.1.2.1	5051137	Hose Barb Saddle	1
29.1.2.2	5072509	O-Ring	2
29.1.2.3	**	Center Nozzle Body w/Core	1
29.1.2.4	5274862	Center Boomless Nozzle Cap w/Gasket	1
29.1.2.5	5018329	Center Spray Tip	1
29.1.2.6	5088024	Valve (On/Off) Knob w/Diaphragm	1
29.1.2.6.1	5063255	Diaphragm	1
29.1.2.7	5117310	SS Screw, 6mm x 16mm (5/8")	2
29.1.2.8	5006347	SS Nut, 6mm	2

Ref. #	Part #	Description	Qty
29.1.3	5075016	Rubber Grommet	2
29.2	5275122	End Nozzle Assembly (Wet Boom)	2
29.2.1	5002499	Boomless Nozzle Body w/Core (Outer)	1
29.2.2	5072518	Stem O-Ring	1
29.2.3	5072517	Compression O-Ring	1
29.2.4	5010427	Compression Olive	1
29.2.5	5006348	Flynut/Boomless 'Wet' Boom	1
29.2.6	5132073	Nozzle Holder Stem	1
29.2.7	5274861	XT Spray Nozzle, Cap, & O-Ring	1
29.2.8	5088024	Valve (On/Off) Knob w/Diaphragm	1
29.2.8.1	5063255	Diaphragm	1

Assemblies Less Tip, Cap & Gasket:
Center Nozzle - #5275621
Outer Nozzle - #5275620

** Only Available in Complete Assembly or Assembly Less Tip, Cap & Gasket

Center Nozzle Assembly 5275123

End Nozzle Assembly 5275122

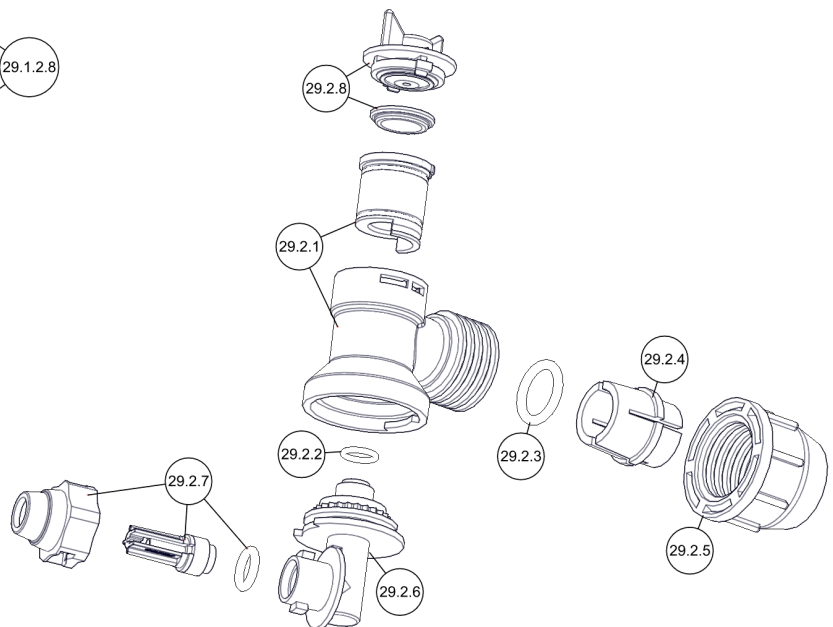
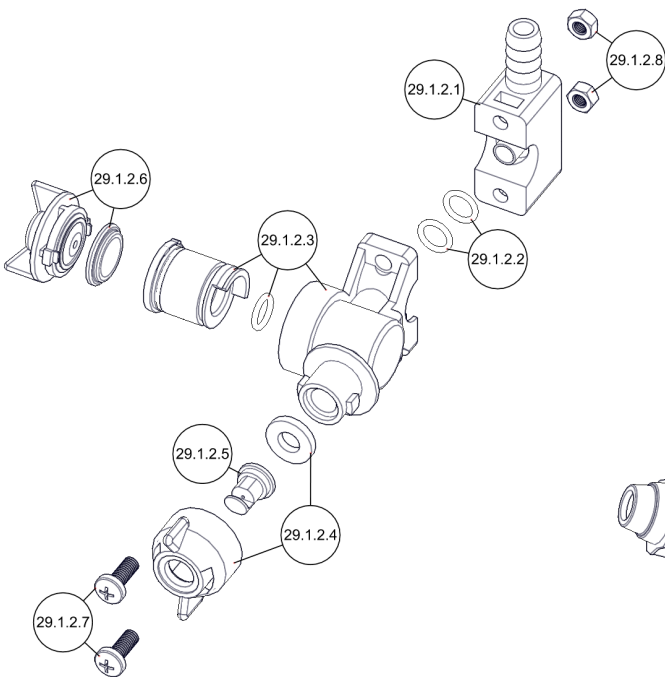

End Nozzle Assembly Procedure For Boomless "Wet" Boom

Your boom will come with the (2) end nozzle assemblies NOT affixed to your boom tube. Follow the instructions below to attach these properly to the boom tube, as shown.

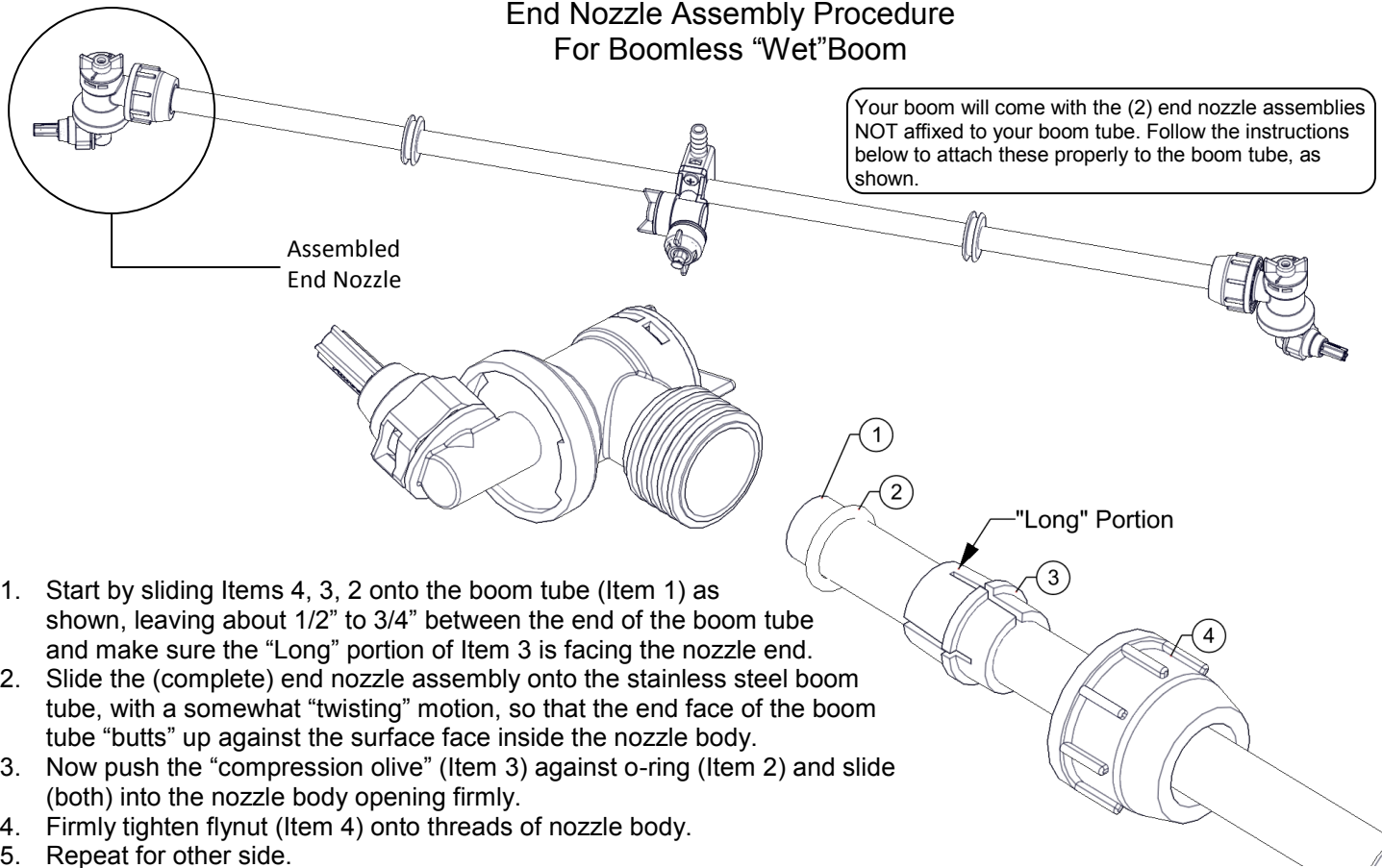

1. Start by sliding Items 4, 3, 2 onto the boom tube (Item 1) as shown, leaving about 1/2" to 3/4" between the end of the boom tube and make sure the "Long" portion of Item 3 is facing the nozzle end.
2. Slide the (complete) end nozzle assembly onto the stainless steel boom tube, with a somewhat "twisting" motion, so that the end face of the boom tube "butts" up against the surface face inside the nozzle body.
3. Now push the "compression olive" (Item 3) against o-ring (Item 2) and slide (both) into the nozzle body opening firmly.
4. Firmly tighten flynut (Item 4) onto threads of nozzle body.
5. Repeat for other side.

End Nozzle Information (5275122)

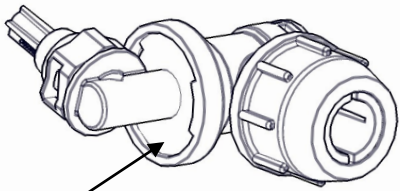

This nozzle mounting stem
Has a ratcheting motion.

** Each "click" of the ratcheting motion is approx. 15° **

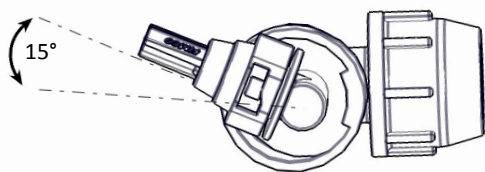

For proper/optimal spray coverage,
The nozzle must be at a 15° angle

The 15° angle shown will prevent the outer
Nozzles from overlapping with the center nozzle.

"On/Off" Valve Positions

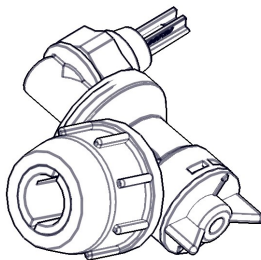

Valve "Open"

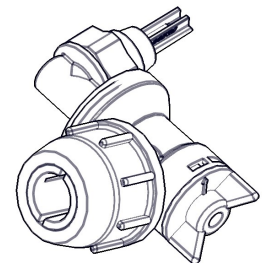

Valve "Closed"

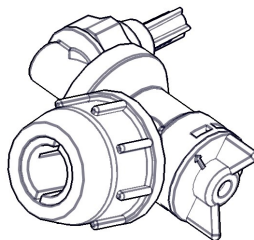

Service Position

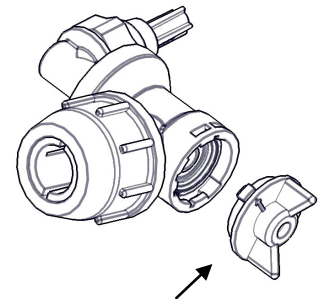

On/Off Valve Knob

Eliminate line pressure, then pull out
to check diaphragm condition.

Note: The check valve & diaphragm can fall out during transport, if the knob is not turned to the "ON" or "OFF" position.

Intake/Siphon Tube/Screen Detail of a Typical L&G/ATV Sprayer (not including the 'EC' Units)

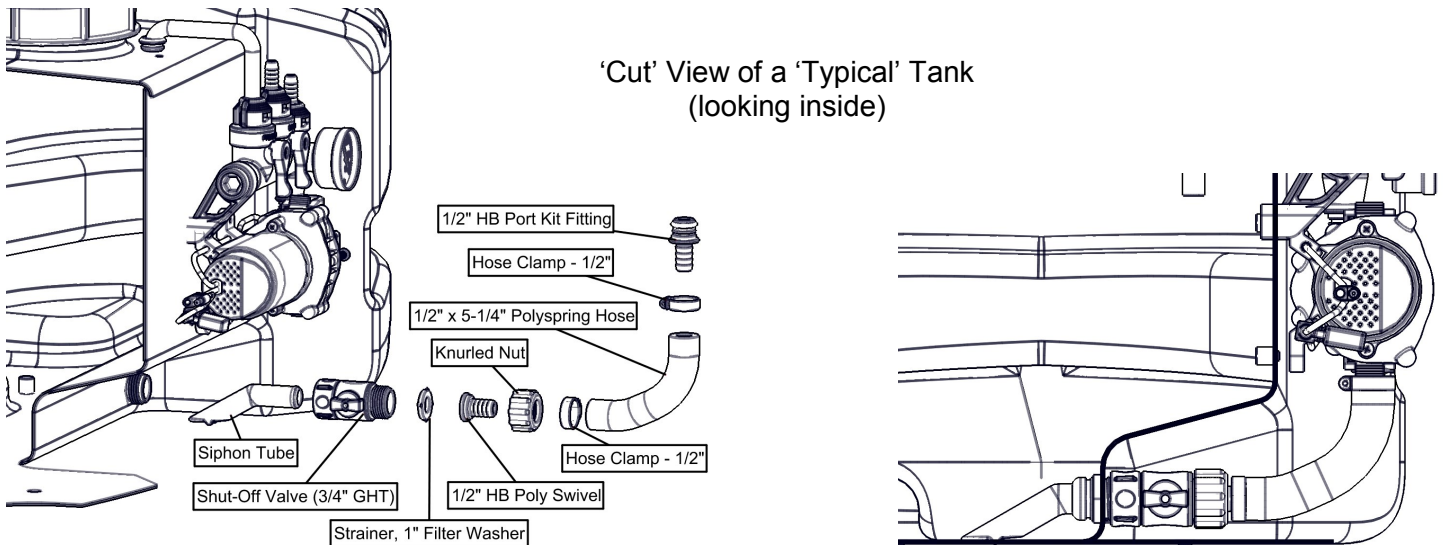

The suction line of your sprayer should contain a 'siphon tube' or intake tube which should be rotated so that it just touches the bottom of the tank surface. (see Detail Views). Reach in and rotate it, as needed, if not already in this position.

A nylon shut-off valve is threaded onto the pipe nipple at the intake location on the tank. It is at this location so you can shut off the flow of solution to access your system's screen for cleaning.

Checking/Cleaning the sprayer's filter/screen:

- ◆ Start your pump and before it shuts off, reach down and Shut the nylon valve to the 'Closed' position (lever is perpendicular to the flow of fluid), then shut off your pump.
- ◆ Unscrew the knurled nut from the shut-off valve, leaving the valve connected to the tank.
- ◆ Swing (swivel) the intake assembly towards you. Look in the nut you JUST unscrewed. There is a screen/washer there.
- ◆ Remove the screen and clean as necessary. Replace when done and reassemble the entire assembly.
- ◆ Make sure the valve is turned to the 'Open' position before restarting your pump.

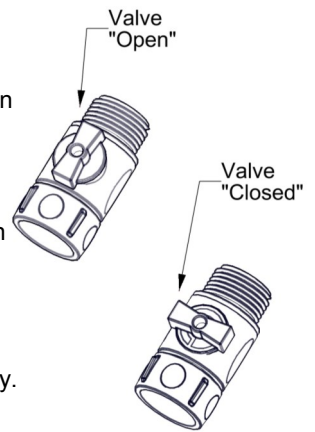

Maintenance During/After Spraying

Periodically check the strainer and clean the screen on your intake line. Proper care and maintenance will prolong the life of your sprayer.

After use, fill the sprayer half way with clean water. Start the pump and allow the water to pump through the entire plumbing system and nozzles. Drain and then refill half full, add the recommended amount of a good quality tank cleaner, such as FIMCO Tank Neutralizer and Cleaner. (If no tank cleaner is available, you may substitute dish soap for this step). Turn pump on and circulate through system for 15 minutes and then spray out through boom and handgun nozzles. Refill sprayer half way with clean water and repeat. Follow the chemical manufacturer's disposal instructions of all wash or rinsing water.

If boom or handgun nozzles need cleaning, remove them from the sprayer and soak in warm soapy water. Clean with a soft bristled brush or toothpick if necessary. Never use a metal object. Even the slightest damage can change the flow rate and spray distribution. Water rinse and dry the tips before storing.

WARNING: Some chemicals will damage the pump valves if allowed to soak untreated for a length of time! ALWAYS flush the pump as instructed after each use. DO NOT allow chemicals to sit in the pump for extended times of idleness. Follow the chemical manufacturer's instructions on disposal of all waste water from the sprayer.

Storing Sprayer

When sprayer is not in use, release Cam Lock Handles. This is to prevent deforming of Cam Lock Mechanism. Do not use QR bracket Cams to hold and store boom in vertical position.

Winter Storage

Before storing your sprayer for winter or long term storage, thoroughly clean and drain it as much as possible. Then pour enough pink RV antifreeze into the tank so that when the pump is turned on you can pump the antifreeze throughout the entire plumbing system, including the bypass. Make sure to operate the boom and handgun until you see pink fluid spraying from the nozzles. Leave any remaining antifreeze in the tank. Before your next usage, rinse the antifreeze from the sprayer with clean water.

It is nearly impossible to drain all of the water from the sprayer and any trapped water can freeze in cold weather and damage parts of the sprayer. Pumping the antifreeze through the system will displace the water and help prevent this damage.